

Type A Bushed

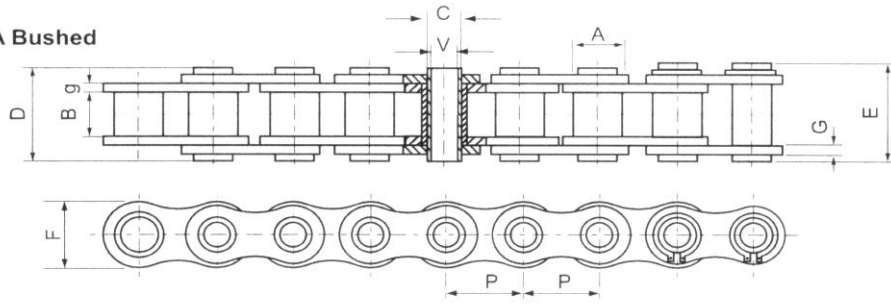

Type C Roller

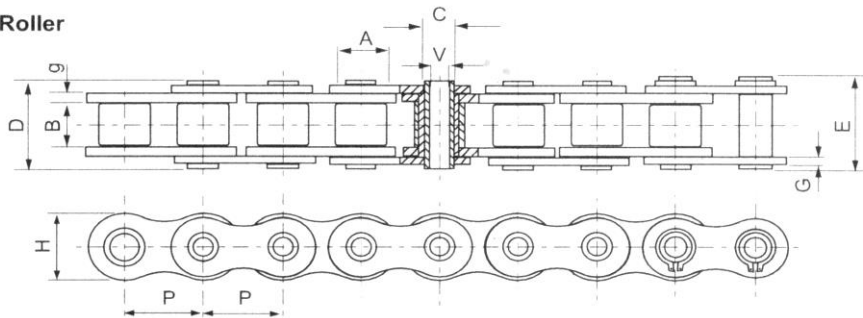

Chain	Roller diameter		Inner width		Pin			Plate		Min. tensile strength kN	Average tensile strength kN	Mass per meter kg/m	Type
	P	A	B	C	V	D	E	F	g				
08BHP	12,700	8,51	7,75	6,55	4,50	16,40	17,60	11,80	1,60	11,10	12,10	0,56	A
10BHB	15,875	10,16	9,65	5,94	4,04	19,03	20,60	14,70	1,70	17,00	20,80	0,86	C
12BHP	19,050	12,07	11,68	6,50	4,00	21,60	22,80	15,90	1,85	23,60	25,90	1,09	C
40HP	12,700	7,95	7,85	5,63	4,00	16,50	17,60	12,00	1,50	11,00	12,20	0,54	A
50HP	15,875	10,16	9,40	7,03	5,13	20,70	21,90	15,09	2,03	20,00	22,60	0,91	A
60HP	19,050	11,91	12,70	8,31	6,00	25,80	26,80	18,00	2,42	24,00	26,90	1,29	A
60HB	19,050	11,91	12,70	7,00	5,01	25,50	26,60	18,00	2,42	20,00	22,40	1,35	C
80HP	25,400	15,88	15,75	11,40	8,05	32,50	33,80	24,00	3,25	50,00	58,30	2,26	A